

Oilstick Magnum

Oilstick Magnum with F2K Dispenser
Article no. Z-B 1000 1043



Included

F2K Dispenser
Article no. Z-Q 0200 0015

Thread -08



Additional equipment

F2K Receiver
Article no. Z-Q 0200 0014

Thread -08

Oilstick Magnum with LiTec Dispenser
Article no. Z-B 1000 1026



Included

LiTec Dispenser
Article no. Z-Q 0001 8046

Thread -08



Additional equipment

LiTec Receiver
Article no. Z-Q 0001 8034

Thread -08

Key features

- Pressurized bottle to refill oil up to 1.8 litres, for example in the pit lane
- Total capacity: 2.2 litres
- Weight: approx. 970 g
- Working pressure: 6 bar (tested 25 bar)
- Easy to fill; pressurize with Schrader valve, easy to stick onto the receiver nipple
- Dry break, no spillage

Oilstick Magnum

Measures

Oilstick Magnum with LiTec Dispenser Article no. Z-B 1000 1026

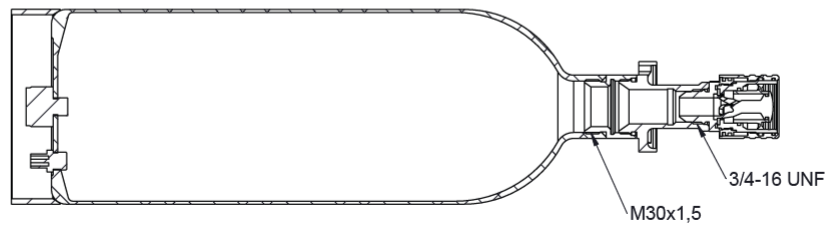
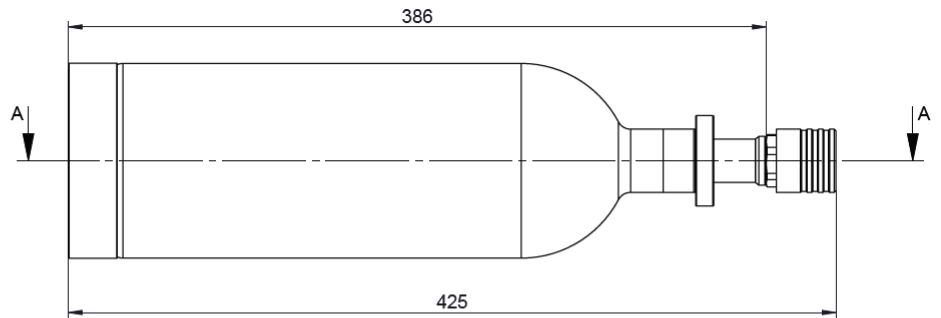
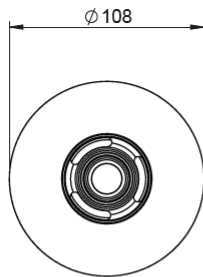

SECTION A-A

Oilstick Magnum with F2K Dispenser Article no. Z-B 1000 1043

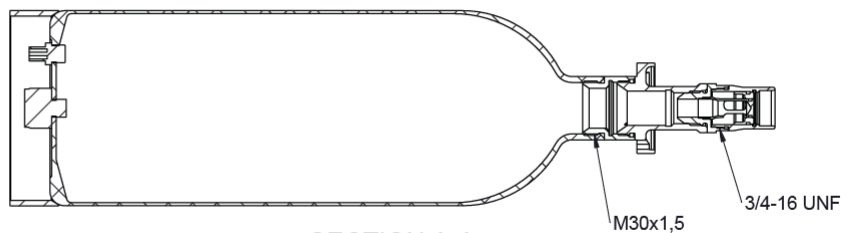
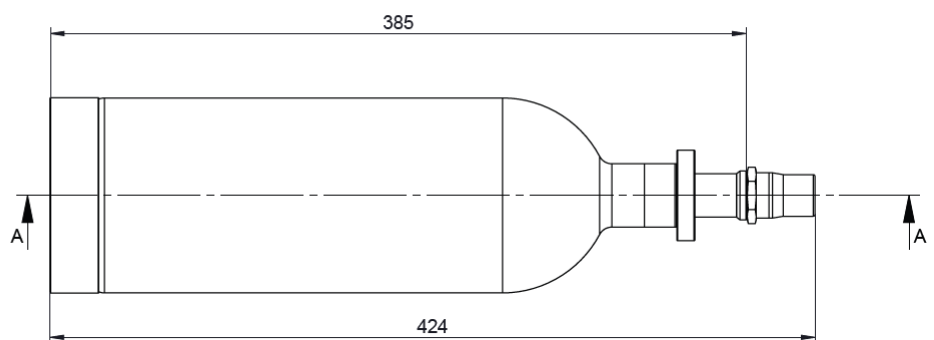
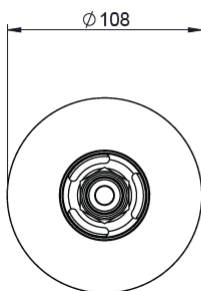

SECTION A-A