

ASOV SL – straight line – Automatic Shut-Off Valve – according to FIA Appendix J, Article 253 3.3

Compact an light weight shut-off valve for the fuel system; identification of leakage by pressure loss; flow-optimized design with minimized back pressure drop for the entire fuel system.

SOBEK Article no.: Z-V 0067 0130

FORM

- Weight 43 g
- Length 68,5 mm
- Material EN-AW 7075, anodized surface

FIT

- IN: 9/16-18UNF / -06 male
other connectors on request
- OUT: 9/16-18UNF / -06 male
other connectors on request
- Application: Fuel system

FUNCTION

- Automatic shut-off in case of leakage in the fuel system
- Opening pressure 4,0 bar / closing pressure 3,2 bar
- Pressure build-up via internal bypass hole
- Priming by red sliding sleeve

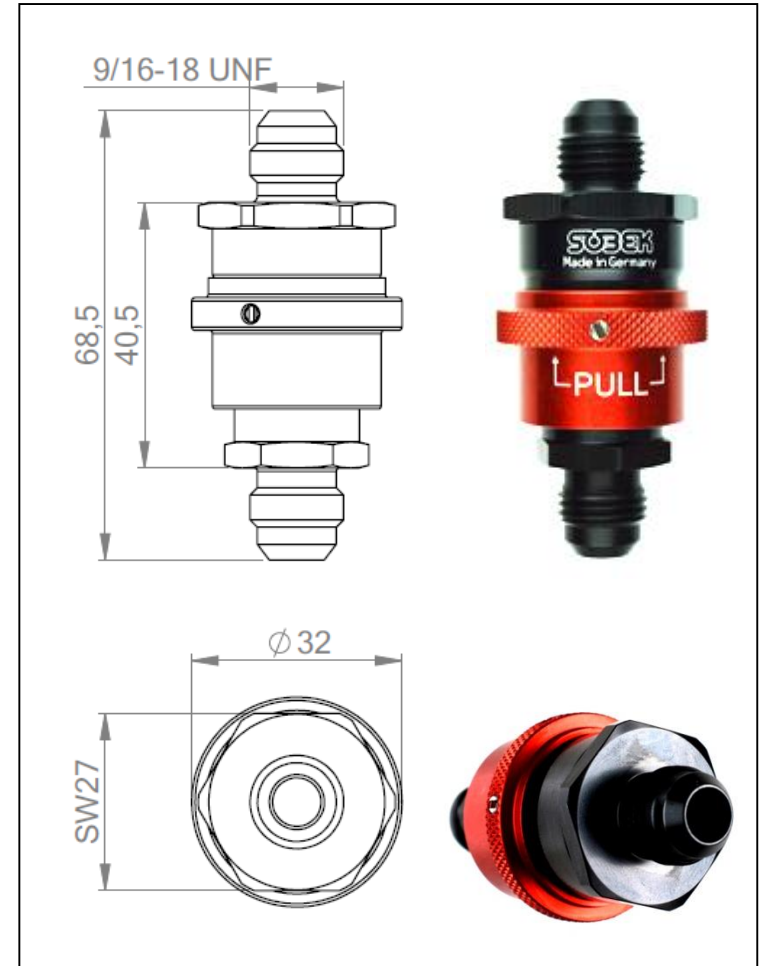

ASOV SL – straight line – Automatic Shut-Off Valve – according to FIA Appendix J, Article 253 3.3

Compact and light weight shut-off valve for the fuel system; identification of leakage by pressure loss; flow-optimized design with minimized back pressure drop for the entire fuel system.

SOBEK Article no.: Z-V 0067 0131

FORM

- Weight 48 g
- Length 73,6 mm
- Material EN-AW 7075, anodized surface

FIT

- IN: 9/16-18UNF / -06 female
other connectors on request
- OUT: 9/16-18UNF / -06 male
other connectors on request
- Application: Fuel system

FUNCTION

- Automatic shut-off in case of leakage in the fuel system
- Opening pressure 4,0 bar / closing pressure 3,2 bar
- Pressure build-up via internal bypass hole
- Priming by red sliding sleeve

